



Item #: _____

Models: MCO-G-5/25-L/R

Product Name: Master Half-Size Gas
Convection Oven*Model MCO -G-5-R***Specification:**

Garland Master Half-Size gas convection oven. 60,000 BTU (17.6 kW) / cavity, 1/3HP fan motor with 2-speed fan control. Electronic spark ignition. Porcelain enameled oven interior with coved corners, 5 oven racks and 7-position rack guides, measures 14-1/4" (362mm) wide x 20" (508mm) high x 20-3/4" (527 mm) deep. Stainless steel front, top, and sides. RH or LH control (specify).

UL, CUL Gas-Fired and NSF Listed.

GAS-FIRED**GAS-FIRED****Standard Features:**

- Master 200 Solid State control with 150°F (66°C) to 500°F (260°C) temperature range, and 60 minute electromechanical timer
- Electronic spark ignition, including automatic pilot system with 100% safety shut off
- 2-speed fan control w/1/3HP fan motor
- Total of 60,000 BTU (17.58 kW) loading per oven cavity
- Natural or propane gas
- Stainless steel front, sides, and top
- Single door w/double pane thermal window
- Control panel on RH side w/door hinged on LH side, "-L" models; control panel on LH side with door hinged on RH side, "-R" models
- 6" (152mm), adjustable stainless steel legs
- Porcelain enameled oven interior with coved corners
- 5 chrome plated oven racks on 7-position rack guides
- Double deck models available (change-5 to -25)
- One year limited parts & labor warranty (USA & Canada only)
- Five year limited door warranty, excluding window (USA & Canada only)

Optional Features:

- Extra oven racks
- Swivel casters with front brakes, (not available for single-deck models)
- Stainless Steel open base (34-1/2" (876mm) high) with rack guides, shelf, and **square tubular legs** - for extra rack/pan storage
- Stainless Steel open base (34-1/2" (876mm) high) with rack guides, shelf, and **casters** - for extra rack/pan storage
- Direct connect vent (specify single or double deck)
- Stainless steel canopy diverter
- Solid stainless steel door, (no additional charge)
- 3/4" gas flex hose and quick disconnect
- Deck fasteners, (flanged feet)
- Stainless steel main back

NOTE: Ovens supplied with casters must be installed with an approved restraining device.

Garland Commercial Industries, Inc.
185 East South Street
Freeland, Pennsylvania 18224
Phone: (570) 636-1000
Fax: (570) 636-3903

Garland Commercial Ranges Ltd
1177 Kamato Road, Mississauga, Ontario
L4W 1X4 CANADA
Phone: 905-624-0260
Fax: 905-624-5669

Enodis UK LTD
Swallowfield Way, Hayes, Middlesex
UB3 1DQ ENGLAND
Telephone: 081-561-0433
Fax: 081-848-0041

Garland®

GAS

Master Half-Size Gas Convection Oven

Models: MCO-G-5/25-L/R

Models: MCO-G-5/25-L/R

Master Half-Size Gas Convection Oven

GAS

Garland®



Item #: _____

Models: MCO-G-5/25-L/R

Product Name: Master Half-Size Gas Convection Oven

MODEL NUMBER	NATURAL GAS	PROPANE	ELECTRICAL SUPPLY
		4.0" WC, (10 mbar)	10.0" WC, (24.9 mbar)
MCO-G-5L MCO-G-5R	60,000 BTU/hr (17.6 kW/hr) Orifice #37 DMS	60,000 BTU/hr (17.6 kW/hr) Orifice #51 DMS	Single Phase 60Hz, 6.0 Amps 6-ft. Line Cord Supplied
MCO-G-25L MCO-G-25R	120,000 BTU/hr (35.2 kW/hr) Orifice #37 DMS	120,000 BTU/hr (35.2 kW/hr) Orifice #51 DMS	Single Phase 60Hz / 6.0 Amps (2) 6-ft. Line Cords Supplied

INTERIOR DIMENSIONS, (PER DECK)				SHIP WT.	SHIP SIZE
MODEL #	WIDTH	HEIGHT	DEPTH	lbs. / kg	Cube
MCO-G-5	14.25 (362mm)	20 (508mm)	20.75' (527mm)	435/195	38.5
MCO-G-25	14.25 (362mm)	20 (508mm)	20.75' (527mm)	870/390	77

Models shown are:

L, with controls on right side and the door hinged on left side;
R has controls on left side with door hinged on right side.

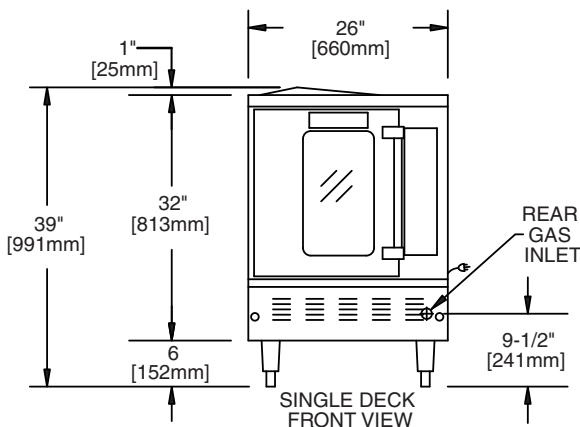
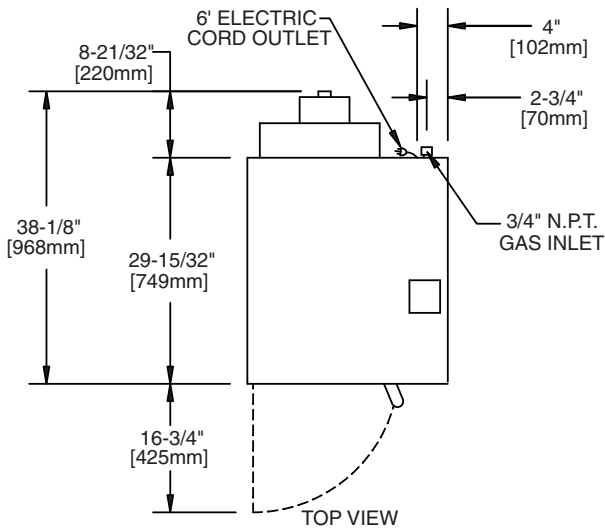

Gas Inlet: One @ 3/4" NPT Single Deck
One @ 1" NPT Double Deck

Gas Input Ratings shown here are for installations up to 2,000 ft. (610mm) above sea level. Specify altitudes over 2,000 ft.

Please specify gas type when ordering.

Garland/U.S. Range products are not approved or authorized for home or residential use, but are intended for commercial applications only. Garland / U.S. Range will not provide service, warranty, maintenance or support of any kind other than in commercial applications.

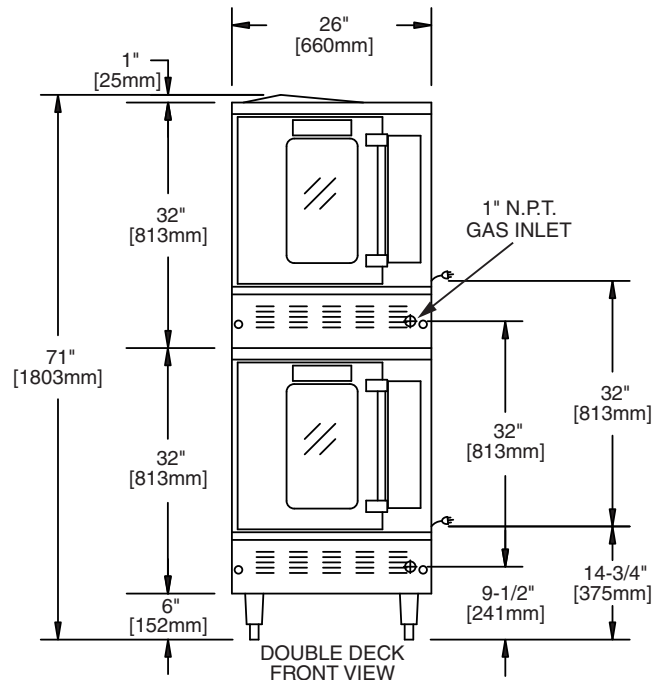

Continuous product improvement is a Garland policy.

Printed in USA

Specifications and design are subject to change without notice.

Form #MCOG5 (07/07)